

BRUSHING MACHINE SBM-M B2



Operating panel



B-aggregate



Brushing tool

LISSMAC systems for metal processing set benchmarks in innovative sheet metal processing through highly-effective, two-sided removal of oxide layers on lasered sheets using only one work process. Unlike brush machines, SBM-M B2s win over customers with more efficient processing work savings of up to 60%.

- Oxide removal in one single pass on all inside and outside edges of sheet and plate up to 20 mm material thickness
- No need to turn sheets over and running them through the machine again
- Up to 60 % work time savings compared to one-side processing brush machines
- Highest quality during subsequent processing or finishing
- Simultaneous brushing of interior and exterior contours
- All sharp edges blended
- Improved surface quality from removal of rust, scale and dirt
- Protective oil film remains intact
- The cross-machining principle guarantees optimum tool utilisation over the entire working width.
- Simple, intuitive operation
- Faster and simpler tool change within just a few minutes
- Modular and compact in modern machine design - smaller footprint
- Improved work environment - Reduction of dust, dirt and noise
- Optionally available: Conveyor Technology; Handling Systems, Automation; Custom Solutions



[1]

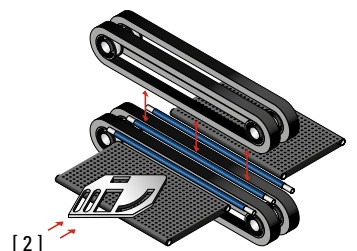

[2]

[1] M-series features with each two units on the top and the bottom

[2] 2/2-units can be equipped with various tool options

working width max.	1000 / 1500 mm
workable material thickness	0,5 - 20 mm
load	300 kg/rm
voltage	400 V / 50 Hz
network structure	3~ PEN / 3~ PE+N
total power	43 A
total current consumption	23,5 kW
insulation class	IP 42
infinitely variable feed speed	0-4 m/min.
adjustment of material thickness	electric
adjustment of tools	electric
weight approx.	2000 / 2300 kg
dimensions (W/D/H) approx.	2600/1400/1800 mm 3100/1400/1800 mm

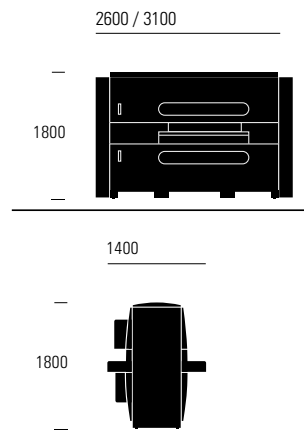

→ LISSMAC Maschinenbau GmbH
Hauptsitz
Lanzstraße 4
88410 Bad Wurzach, Deutschland
Telefon +49 75 64 307-0
Telefax +49 75 64 307-500
lissmac@lissmac.com
www.lissmac.com

Subject to technical change without notice